

## MONTAGGIO ORIZZONTALE - HORIZONTAL ASSEMBLY

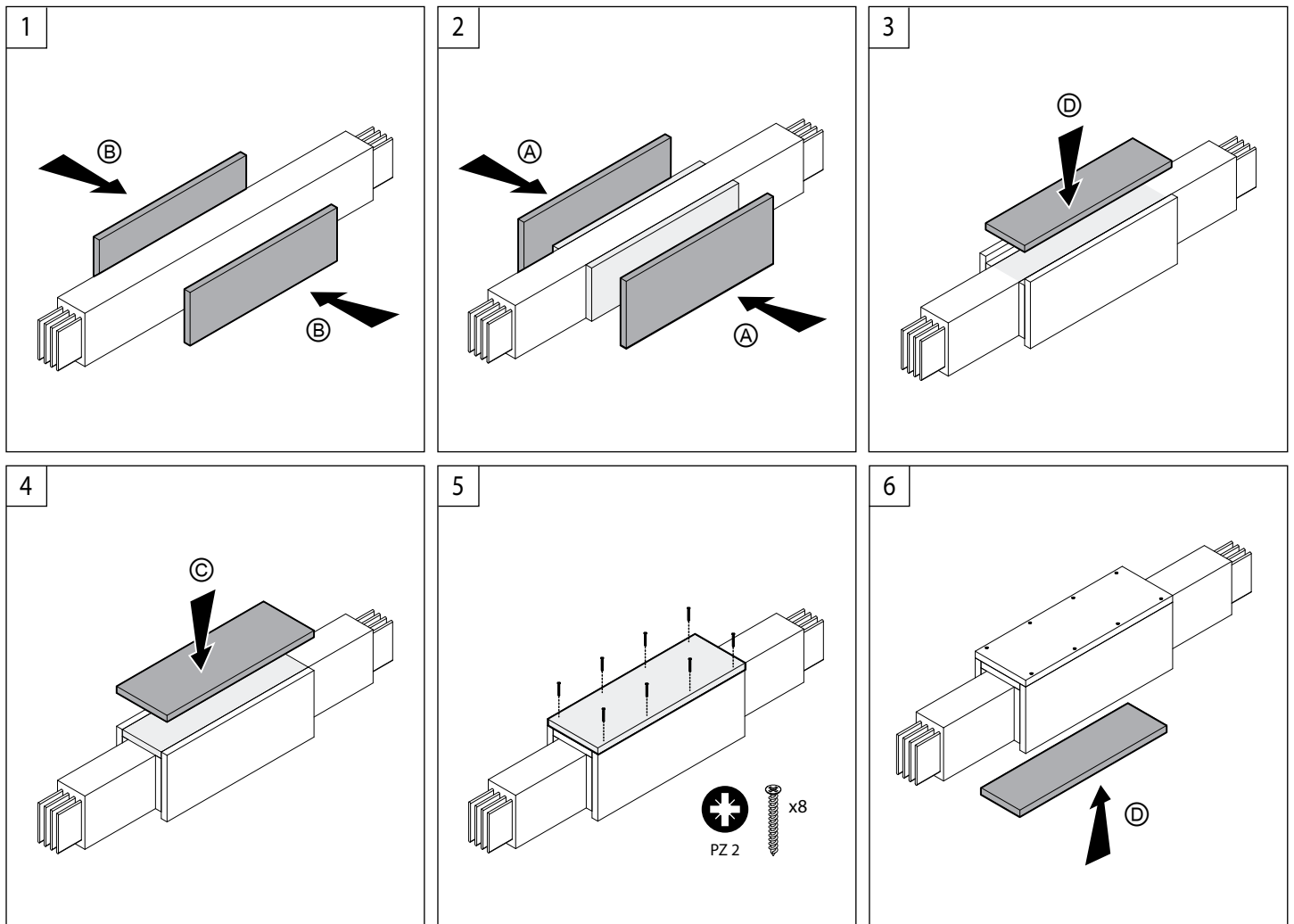

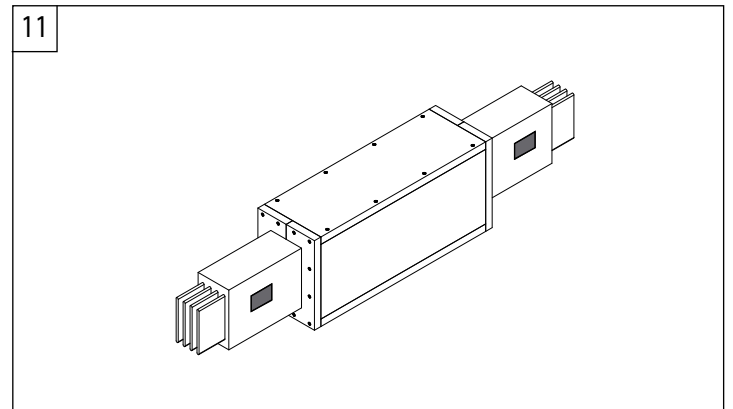

Una volta montata la barriera, riempire tutti gli interstizi tra i pannelli con la pasta Promaseal quindi spatolare i cordoni in modo da ottenere un aspetto liscio ed omogeneo.  
Per agevolare il montaggio tenere in posizione i pannelli con delle morse.  
Finito il montaggio apporre una targhetta prima e dopo il setto.

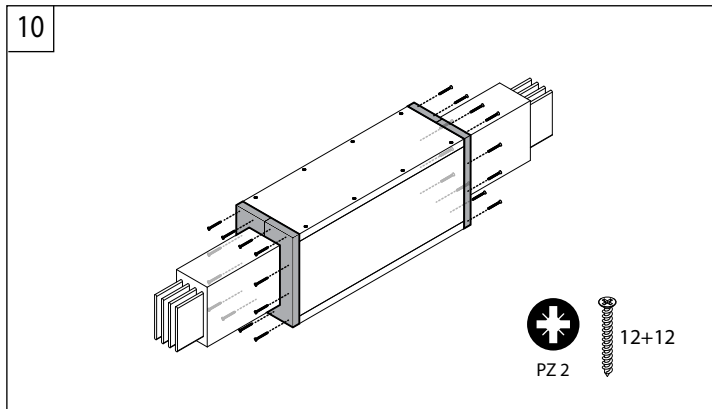
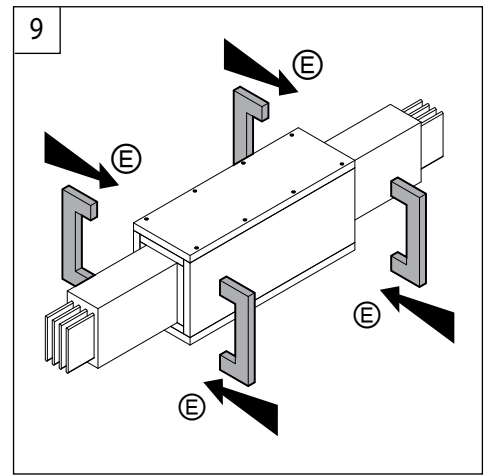
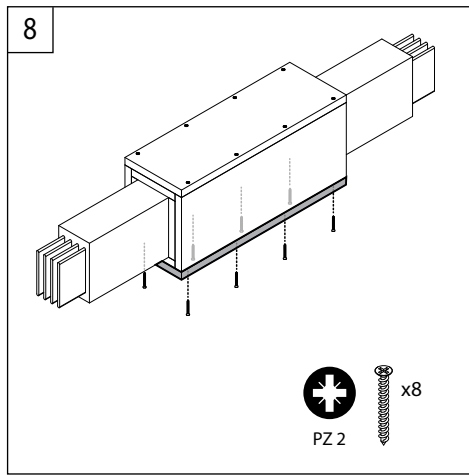
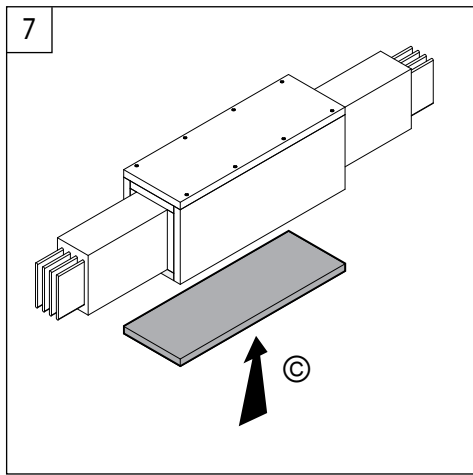

One the barrier is assembled, fill all the joints between panels with the Promaseal paste and then work it with putty knife to obtain a smooth and homogeneous aspect.  
To simplify assembly, keep the panels in position with bench vise.  
After assembly, affix a label before and after the FIRE BARRIER

### MONTAGGIO VERTICALE - VERTICAL ASSEMBLY

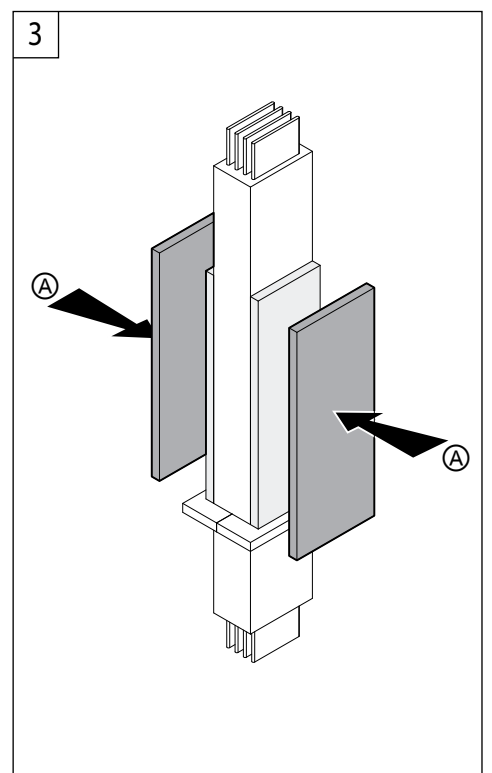
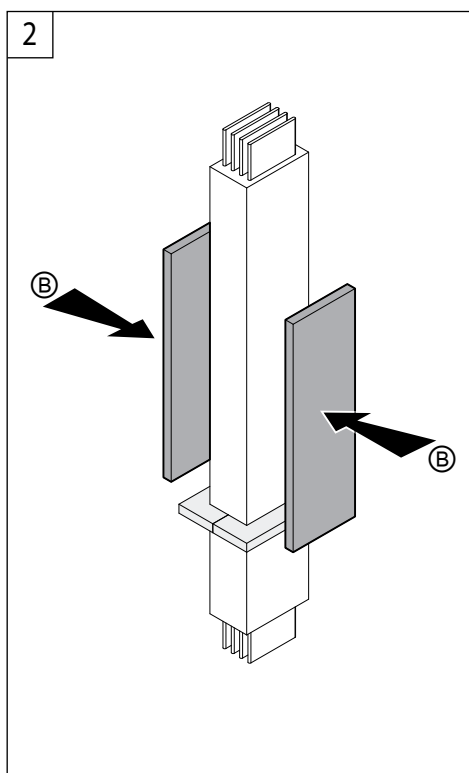
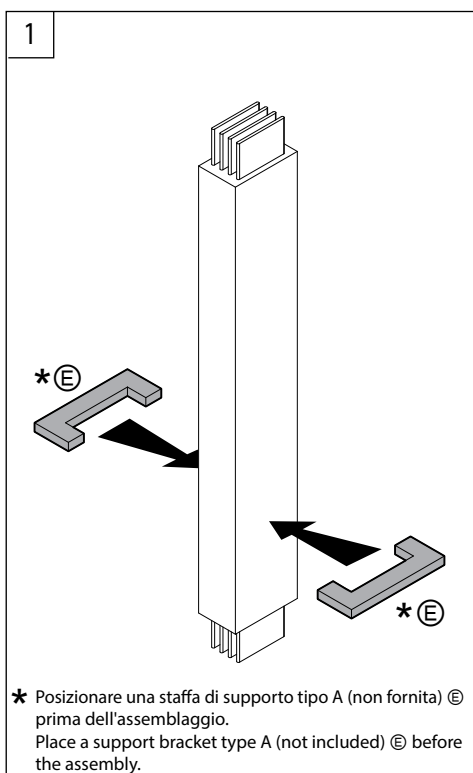

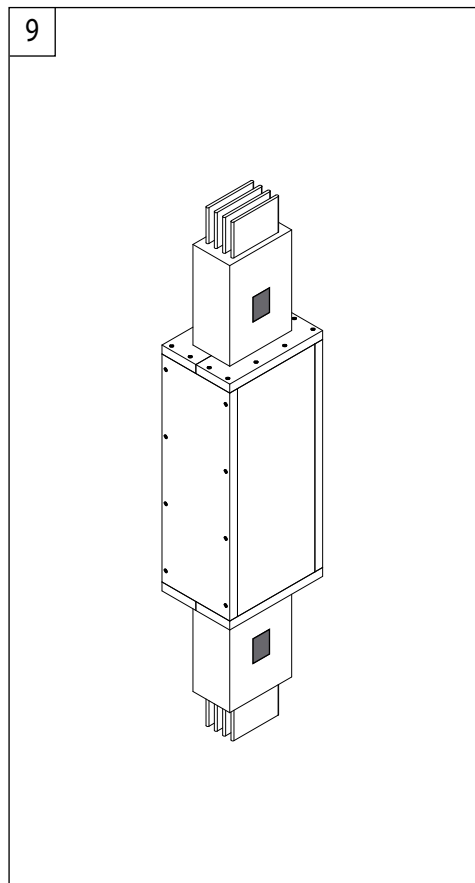
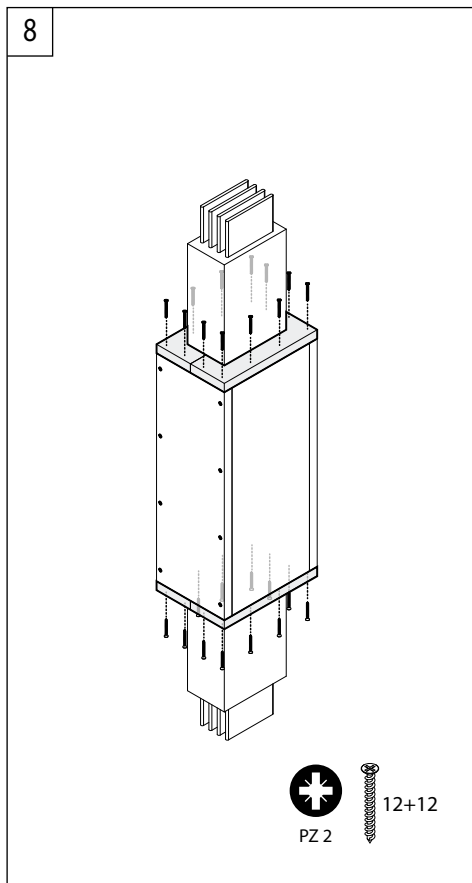
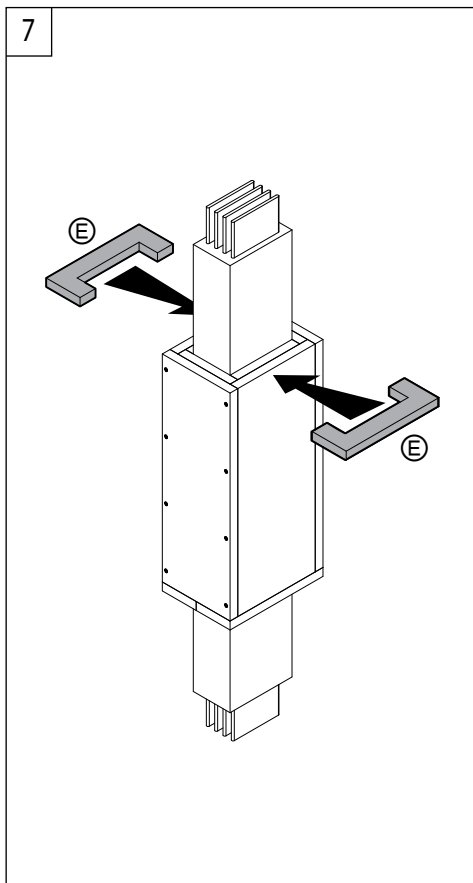
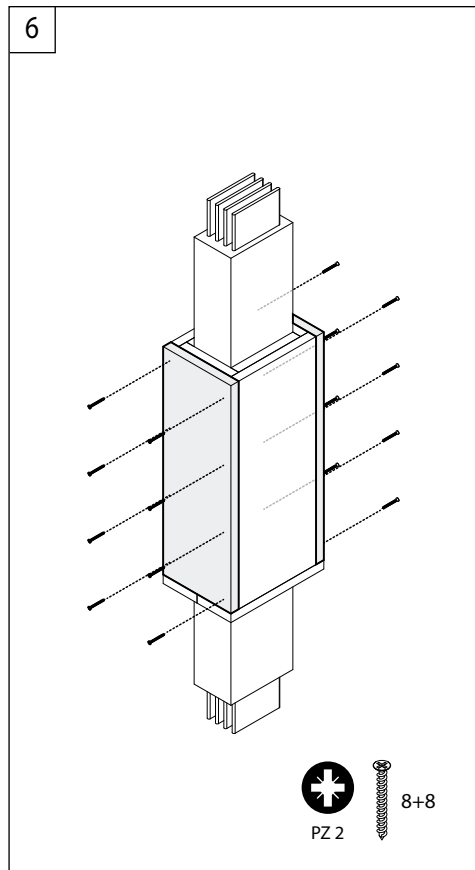
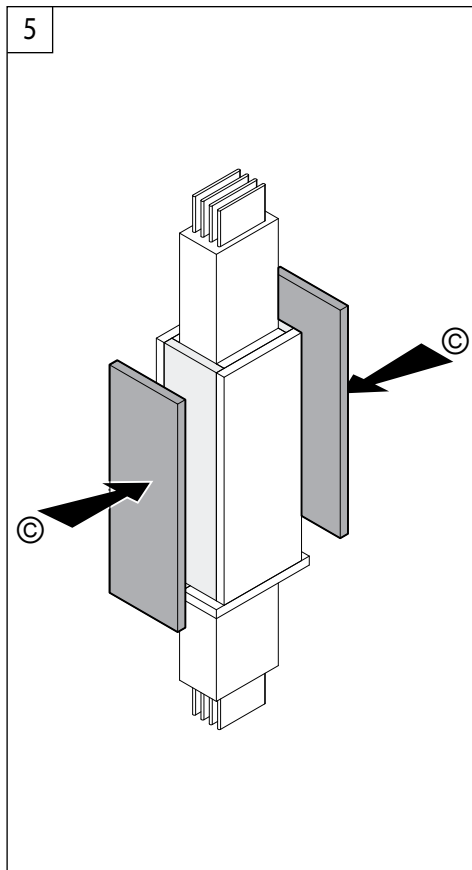
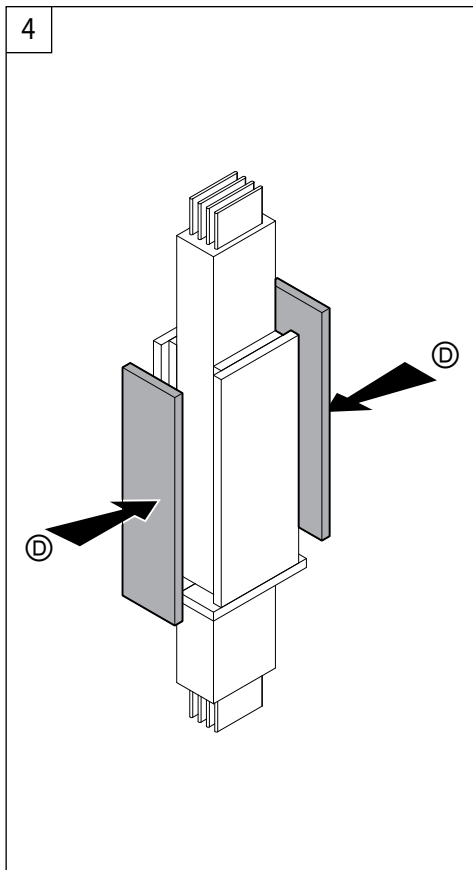

Una volta montata la barriera, riempire tutti gli interstizi tra i pannelli con la pasta Promaseal quindi spatolare i cordoni in modo da ottenere un aspetto liscio ed omogeneo.  
Per agevolare il montaggio tenere in posizione i pannelli con delle morse.  
Finito il montaggio apporre una targhetta prima e dopo il setto.



One the barrier is assembled, fill all the joints between panels with the Promaseal paste and then work it with putty knife to obtain a smooth and homogeneous aspect.  
To simplify assembly, keep the panels in position with bench vise.  
After assembly, affix a label before and after the FIRE BARRIER