

**EMS BTDIN – Signalling Auxiliary
Contact (CA + SD)**Cat. N°:
F80BCR

Contents	Pages
1. Description - Use	2
2. Range	2
3. Overall dimensions	2
4. Preparation - Connection	2
5. General characteristics	5
6. System architectures	9
6.1 Stand-alone	9
6.1.1 with local addressing	9
6.1.2 with remote addressing	10
6.2 Supervised	11
6.2.1 with local addressing	11
6.2.2 with remote addressing	13
7. Compliance and approvals	15

EMS BTDIN - Signalling Auxiliary Contact (CA + SD)

Cat. N°:
F80BCR

1. DESCRIPTION - USE

- . Module dedicated to Energy Management System (EMS BTDIN) use.
- . Auxiliary and Fault signalling electronic module (CA+SD): indicates contacts position (open or closed) and fault tripping of BTicino modular associated device (MCB, RCBO, RCCB or Remote trip head IS).

Symbol:



2. RANGE

- . Cat. n° F80BCR: electronic auxiliary contact (CA) + fault signalling (SD).

Width:

- . 1/2 module. 8,8 mm width.

3. OVERALL DIMENSIONS

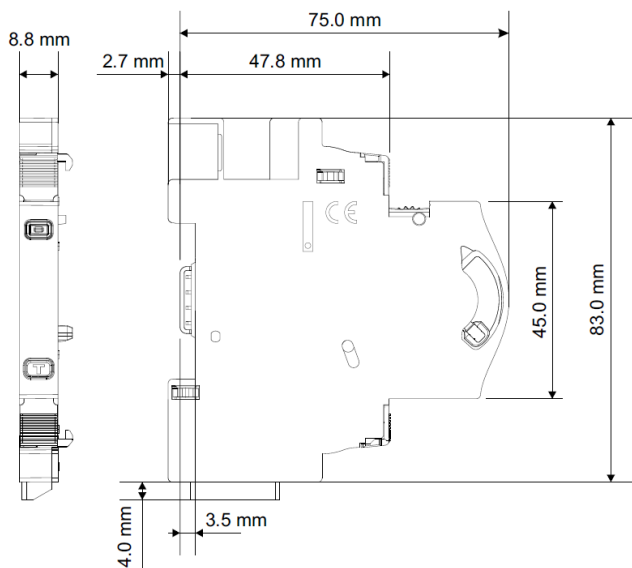

4. PREPARATION -CONNECTION

Fixing:

- . On symmetric rail EN/IEC 60715 or DIN 35 rail

Operating positions:

- . Vertical, Horizontal, Upside down, On the side



4. PREPARATION -CONNECTION (continued)

Power Supply:

- . Mandatory in 12 VDC via the specific Power supply module Cat n° F80BA
- . Two ways:
 - via specific communication patch cords (cat. nos F80BC250/500/1000) to connect at the downstream through dedicated ports

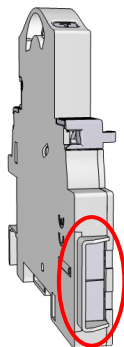

via specific communication rails (cat. nos F80BR18/24/36) to connect at the rear through dedicated connectors.

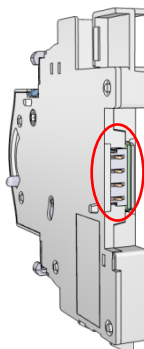

Manual action of the CA + SD:

- . By the handle of the associated device.

Assembling:

- . On the left side of BTicino MCB, IS, RCBO or RCCB
- . No tools are required. Clipped by mean of plastic clamps on the associated device.
- . Assembling products in OFF position
- . The switching device of signalling auxiliaries must fit into the housing of the handle of the associated device.

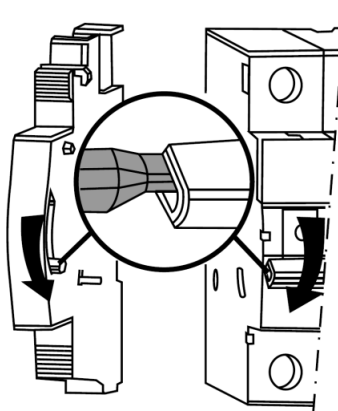

EMS BTDIN - Signalling Auxiliary Contact (CA + SD)

Cat. N°:
F80BCR

4. PREPARATION –CONNECTION (continued)

Assembling (continued):

List of allowed associations (General rules):

Three auxiliaries maximum which:

- two signalling auxiliaries (Cat. nos F80CA/CA05, F80RC05, F80CR/CR05, F80BCR).
- only one control auxiliary (Cat. nos F80ST1/ST2, F80SV1/SV2, F80SVE1/SVE2, F80SVP).

. If signalling and control auxiliaries are associated on the same circuit breaker, the control auxiliary must be placed to the left of the signal auxiliary (cat. nos F80CA/CA05, F80RC05, F80CR/CR05 or F80BCR).

List of allowed associations (Particular rules):

- . With MCB's 1,5 modules per pole width:
 - **if a remote tripping auxiliary** (Cat. nos F80ST1/ST2, F80SV1/SV2, F80SVE1/SVE2, F80SVP) **is already mounted** on this kind of device, only 1 module width signalling auxiliaries (Cat. nos. F80CA or F80CR) can be added.
 - In this set up the ½ module signalling auxiliaries will not operate. Nothing changes for the other modular references.
- . With an isolating switch BTDIN-IS:
 - only one signalling auxiliary CA type (Cat. nos F80CA/CA05, F80CR/CR05) or CA+SD (Cat. n° F80BCR).
- . With a remote trip head isolating switch BTDIN-IS, three auxiliaries maximum which:
 - one or two signalling auxiliaries CA type (Cat. nos F80CA/CA05, F80CR/CR05) or CA+SD (Cat. n° F80BCR).
 - one control auxiliary (Cat. nos F80ST1/ST2, F80SV1/SV2, F80SVE1/SVE2, F80SVP).

Combination tables of the auxiliaries:

. For devices 1 module per pole width:

			F80RC05 F80CR F80CA F80RC F80CA05 F80CR05 F80BCR	F80ST1 F80ST2 F80SV1 F80SV2 F80SVE1 F80SVE2 F80SVE1+F80B F80SVE2+F80B F80SVP
	F80RC05 F80S....	F80CA05 F80CR05	F80RC05 F80BCR	F80CA05 F80CR05
	F80RC05 F80CR F80CA F80RC F80ST1 F80ST2 F80CA05 F80CR05	F80SV1 F80SV2 F80SVE1 F80SVE2 F80SVE1+F80B F80SVE2+F80B F80SVP F80BCR	F80CR F80CA F80RC	
F80ST1 F80ST2 F80SV1 F80SV2 F80SVE1 F80SVE2 F80SVE1+F80B F80SVE2+F80B F80SVP	F80RC05 F80BCR	F80CA05 F80CR05	F80RC05 F80BCR	F80CA05 F80CR05
	F80RC05 F80CR F80CA F80RC	F80BCR		F80CR F80CA F80RC

4. PREPARATION –CONNECTION (continued)

Combination tables of the auxiliaries (continued):

. For devices 1,5 modules per pole width:

		F80RC05 F80CR F80CA F80RC F80ST1 F80ST2 F80SV1 F80SV2	F80SVE1 F80SVE2 F80SVE1+F80B F80SVE2+F80B F80SVP F80CA05 F80CR05 F80BCR
	F80RC05 F80CA05 F80CR05	F80BCR	F80RC05 F80BCR
	F80RC05 F80CR F80CA F80RC F80ST1 F80ST2 F80SV1 F80SV2	F80SVE1 F80SVE2 F80SVE1+F80B F80SVE2+F80B F80SVP F80CA05 F80CR05 F80BCR	F80CA F80CR F80RC
F80ST1 F80ST2 F80SV1 F80SV2 F80SVE1 F80SVE2 F80SVE1+F80B F80SVE2+F80B F80SVP	F80CA F80CR F80RC		F80CA F80CR F80RC

Data connection (EMS BTDIN modules inter-connection):

. Via specific communication patch cords (cat. nos F80BC250/500/1000)



Allow data transmission between the different EMS BTDIN modules. This type of connection is recommended when there are few EMS BTDIN modules, distributed all over the enclosure.

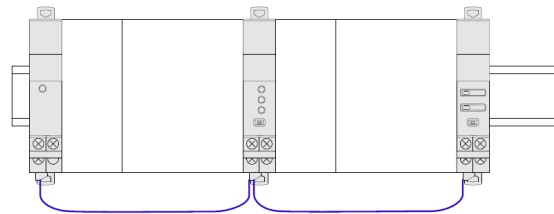

Implementing: with this configuration, the plastic protection cover of the backside communication ports on the EMS BTDIN module must be keep on.

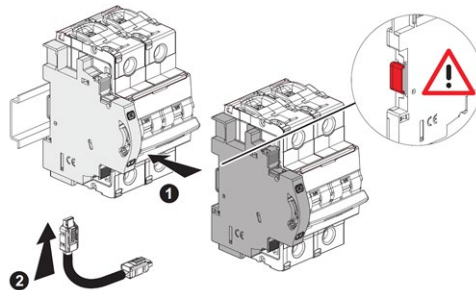

EMS BT DIN - Signalling Auxiliary Contact (CA + SD)

Cat. N°:
F80BCR

4. PREPARATION –CONNECTION (continued)

Data connection (EMS BT DIN modules inter-connection) (continued):

. Via specific communication rails (cat. nos F80BR18/24/36).

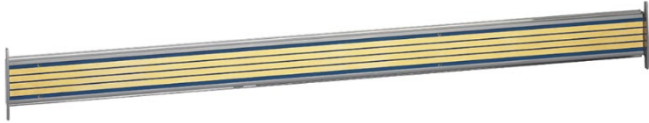

. Allow data transmission between the different EMS BT DIN modules.
This type of connection is recommended when there are several EMS BT DIN modules on the same DIN row.

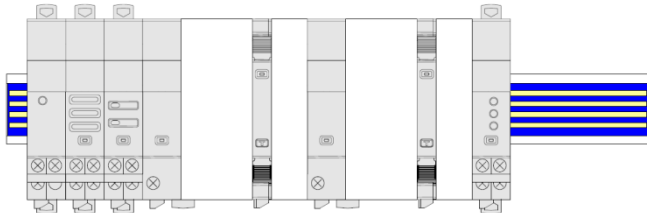

Implementing: with this configuration, the plastic protection cover of the backside communication ports on the EMS BT DIN module must be removed.

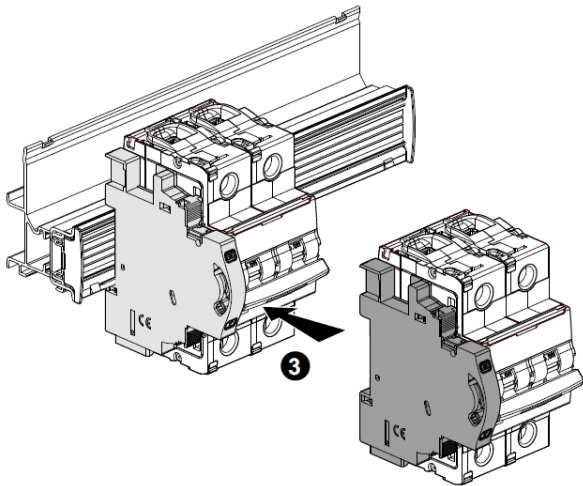
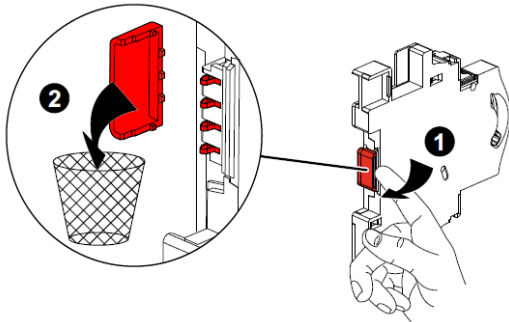

4. PREPARATION –CONNECTION (continued)

Data connection (EMS BT DIN modules inter-connection) (continued):

. Via a mix between specific communication patch cords and communication rails in order to create a link between several rows

Two situations:

- Individually connected with communication rails.
The communication patch cord allows to connect two rows.



- Individually connected with communication patch cords & communication rail.
The communication patch cords allow to connect EMS BT DIN module on a row and to connect two rows.

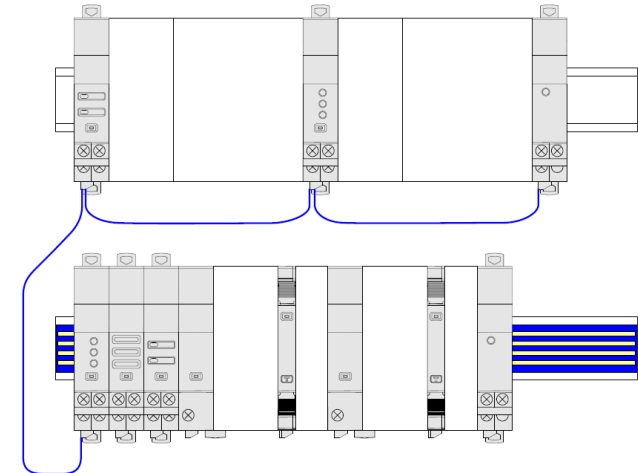

EMS BT DIN - Signalling Auxiliary Contact (CA + SD)

Cat. N°:
F80BCR

5. GENERAL CHARACTERISTICS

Front face marking:

. By permanent ink pad printing (red line) and laser marking

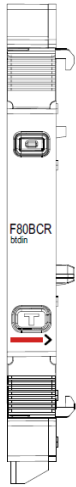

Lateral side marking:

. By laser.

left side: Standard and programming information

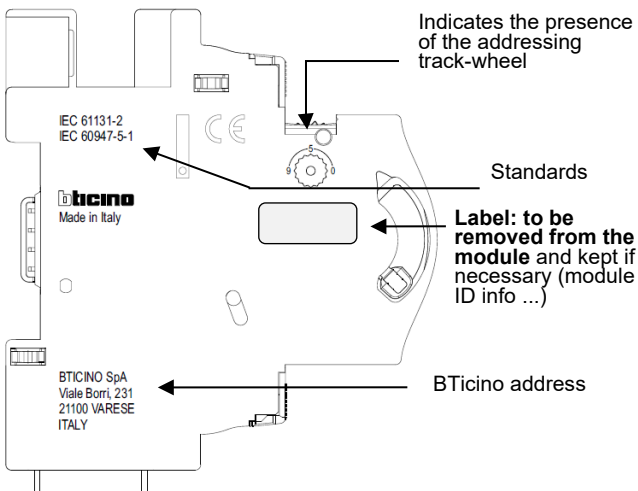

right side: installing and traceability information

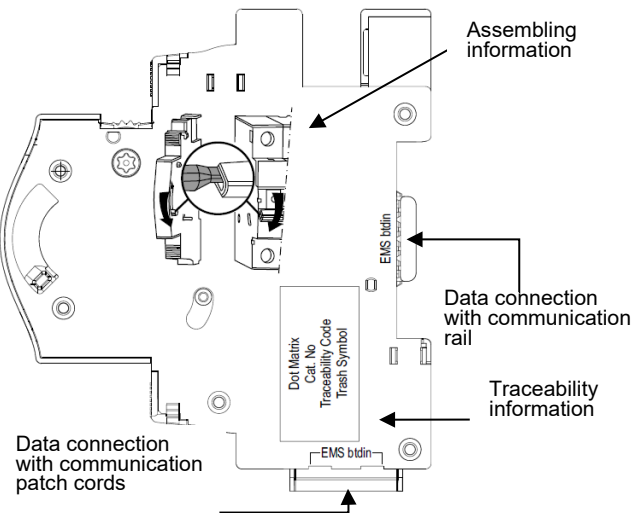

5. GENERAL CHARACTERISTICS (continued)

Test button:

. It allows to check the correct association between the module and the associated device.

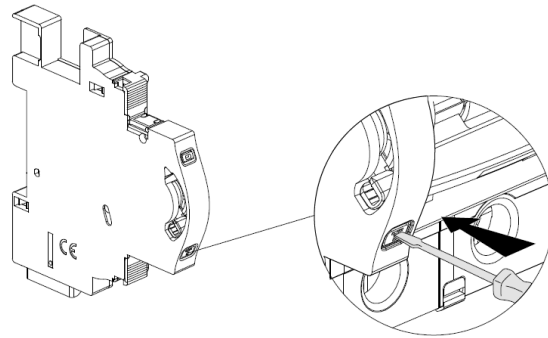

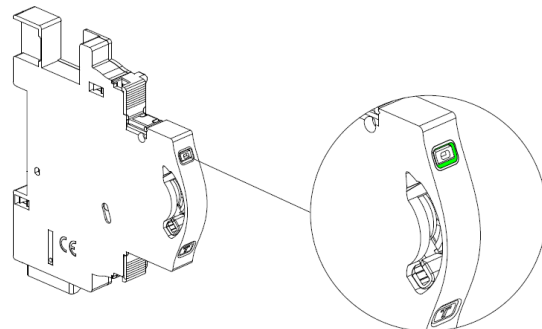

Functions button:

. Front face button as several functions:



. Give information about the operating state on the module

Possible states:

Led colour	State	Meaning
 red	Slow blinking	Error (e.g. addressing error)
	Fast blinking	No function
	Steady (pressing the multifunction button longer than 10 sec.)	Total reset [any firmware updates are preserved]
 green	Slow blinking	System process is running. Wait until the Led turns steady
	Fast blinking (pressing the multifunction button for 5 sec.)	put in "Stand-by" the EMS BT DIN module (no remote action and communication available)
	Steady	System OK, connection is running
 orange	Slow blinking	Creation of a link with "Link Functionality" procedure (see next §)
	Fast blinking	Device's firmware update in progress
	Steady	Start of FW update or active Link functionality (see next §)

5. GENERAL CHARACTERISTICS *(continued)*

Link Functionality:

. This function allows you to link two EMS BT DIN modules to create automatic actions that, once programmed, can run independently without a connection to a manager is needed.

The basic rule is the link between an event (circuit breaker that trip, a threshold exceeded, etc.) and an action accordingly (signalling, opening of a circuit by motorized control or contactor, etc.).

Possible associations are:

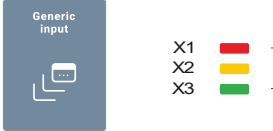
Event generator	Action module		
	Command: F80BC	State + Command: F80BCS	State: F80BV
Measure: F80BM3M63, F80BMM63, F80BMT63, F80BMT125, F80BMT, F80BMR630, F80BMR1600, F80BMR3200, F80BMR6300	✓	✓	✓ Only with the module configured (locally or remotely) as shown: 
State: F80BCR, F80BVS	✓	✓	✗ It's enough to configure the module (locally or remotely) as "Replica"
State + Command: F80BCS	✓	✓	✗ It's enough to configure the module (locally or remotely) as "Replica"

Note:

- association can only be of type 1 to 1 (1 event and 1 action).
- modules already associated cannot be used for other associations.
- all the configuring procedure will be done with the Configuration Software (available online for free). *[For more details refer to the Installation Manual of EMS BT DIN Configuration software]*

5. GENERAL CHARACTERISTICS *(continued)*

Modules compatible with "Link Functionality" feature: firmware versions and production date:

Cat n°	Firmware version	Production date indicated on the label stucked on the side of the module
F80BM3M63	all firmware versions	any production date
F80BMM63	ver. ≥ 2.0.1	date ≥ 18W25
F80BMT63	ver. ≥ 2.0.1	date ≥ 18W49
F80BMT125	all firmware versions	any production date
F80BMT	ver. ≥ 2.0.1	date ≥ 18W35
F80BMR630	all firmware versions	any production date
F80BMR1600	all firmware versions	any production date
F80BMR3200	all firmware versions	any production date
F80BMR6300	all firmware versions	any production date
F80BCR	ver. ≥ 2.0.1	date ≥ 18W47
F80BVS	ver. ≥ 2.0.2	date ≥ 18W35
F80BCS	ver. ≥ 2.0.6	date ≥ 18W45
F80BC	ver. ≥ 3.0.2	date ≥ 18W39
F80BV	ver. ≥ 2.0.4	date ≥ 18W38
F80BIM1	ver. ≥ 3.0.8	date ≥ 18W34

Insulation voltage:

. $U_i = 400 \text{ V}$

Pollution degree:

. 2 according to IEC/EN 60898-1.

Overvoltage category:

. III

Dielectric strength:

. 2500 V

Tripping force:

. Between 1 and 1,5 Nm.

Mechanical endurance:

. These devices support the mechanical cycles of the associated devices
. 20,000 manoeuvres

Plastic material:

. Self-extinguishing polycarbonate.
. Heat and fire resistant according to IEC/EN 60695-2-12, glow-wire test at 960°C.
. Classification UL 94 / IECEN 60695-11-10: V1

EMS BT DIN - Signalling Auxiliary Contact (CA + SD)

Cat. N°:
F80BCR

5. GENERAL CHARACTERISTICS *(continued)*

Ambient operating temperature:

. Min. = -25°C. Max. = +70°C

Ambient storage temperature:

. Min. = -40°C. Max. = +70°C

Protection Index:

. Protection index of terminals against solid and liquid bodies (wired device): IP 20 (IEC/EN 60529).

. Protection index of the front face against solid and liquid bodies: IP 40 (IEC/EN 60529).

Average weight per device:

. 0,032 kg.

Volume when packed:

. 0,21 dm³.

Consumption:

. Values at 12 VDC

0,236 W

19,7 mA

6. SYSTEM ARCHITECTURES

The EMS BT DIN is a polyvalent system and, according to the needs of the customer, can be set up and/or used as "Stand-alone" or "Supervised" system. Based on this choice the configuration and addressing methods are different.

Four possible architectures are provided:

6.1 Stand-alone system

- 6.1.1 with local addressing (through the track wheel)
- 6.1.2 with remote addressing (through a computer)

6.2 Supervised (Computer Supervisory System)

- 6.2.1 with local addressing
- 6.2.2 with remote addressing

6.1 Stand-alone system

. **Stand-alone** = autonomous system. To be used by the end-user if it is not necessary to have a computer for the supervision outside the envelope. Everything can be managed on site.

6.1.1 Stand-alone system with local addressing (through the track wheel)

Local addressing advantages:

- No configuration software needed to set-up the installation
- **It is not necessary to use a computer to manage settings** (configurations, test, ...) and to use the system (visualize and be alerted, ...). Everything can be done through the Mini configuration module (local display, cat. no F80BV). [Refer to the technical sheet dedicated to this module for details].
- No communication Interfaces or gateways are required.
- Installation can be done without the intervention of a System Integrator

Programming procedure:

. For EMS BT DIN modules which need some: mandatory through EMS Configuration software (see § "Module configuration")

Addressing procedure:

. For all EMS BT DIN modules: mandatory through the track wheel located on the top upper face of each EMS BT DIN modules
. Marked from 0 to 9 in order to locally define the Modbus address of the EMS BT DIN modules

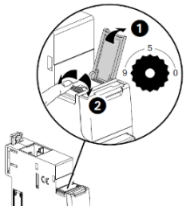

Note for Measure Module "3x single phase":

This module is to be considered as 3 modules with 3 different Modbus Address. The module takes automatically the two addresses immediately following the setting one (e.g. Address set = 2, Addresses of the module 2, 3, 4)

Consequences of the local addressing mode (through the track wheel):

. Each device of the system must be addressed.

- . Addresses available: from 1 to 9
- . Address 0 not permitted

. It is possible to assign to several devices the same address with the purpose of grouping different functions, **because they are related to the same electrical circuit**. For example, it is possible to assign the same address to a signalling auxiliary module (cat. no F80BCR), a universal control module (cat. no F80BC), a measuring module, and so on. In this way on the EMS BT DIN mini configuration module (local display) the grouped function will be displayed as a unique "device" with all grouped functions. [Refer to the schemes hereunder]

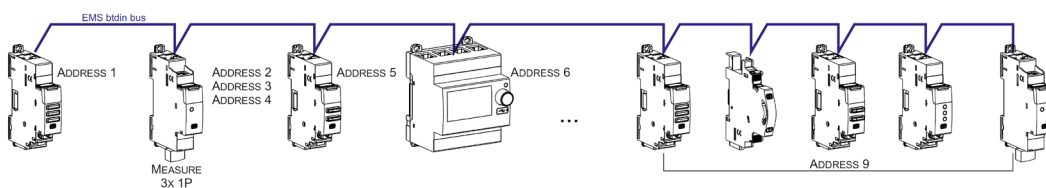

Note for the mini configuration module (local display)

- . It is necessary to assign the mini configurator a different address from all the other EMS BT DIN modules through the device programming menu
- . The mini configuration module can be placed everywhere in the EMS BT DIN bus

6. SYSTEM ARCHITECTURES

6.1 Stand-alone system (continued)

6.1.2 Stand-alone system with remote addressing (through a computer)

Remote addressing advantages:

- Whole configuration (addresses and functions) can be set up through the EMS Configuration software
- Configuration software available for free
- **Automatic detection of the EMS BTDIN modules** installed in the system (characteristics, functions, configuration...)
- **Increased settings possibilities: load shedding function**
- Increased addressing: **up to 30 Modbus addresses in a system**

Programming procedure:

. For EMS BTDIN modules which need some: mandatory through EMS Configuration software (see § "Module configuration")

Addressing procedure:

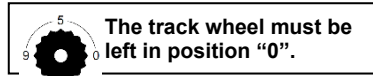
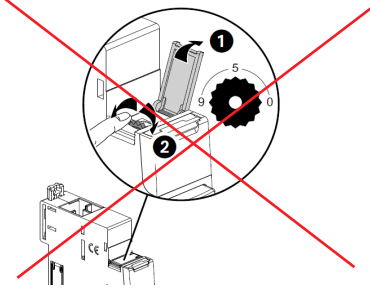

. It is not necessary to assign an address via rotary; **The track wheel must be left in default position "0"**.

. All the addressing/configuring procedure will be done with the Configuration Software (available online for free)

. With remote addressing, the software does the automatic detection of modules installed in the system, but the supervision is not possible until the user assigns the remote address and all the characteristics to each module.

Note: it is mandatory to connect the computer to the mini configuration module with an USB-micro USB cable. [For more details, refer to the technical data sheet of the Mini configuration module EMS BTDIN]

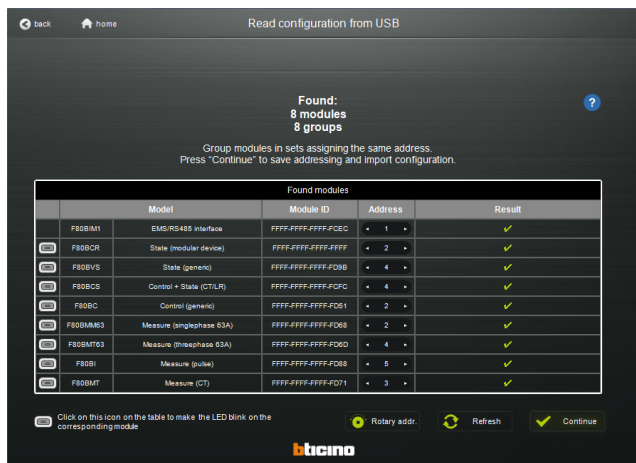
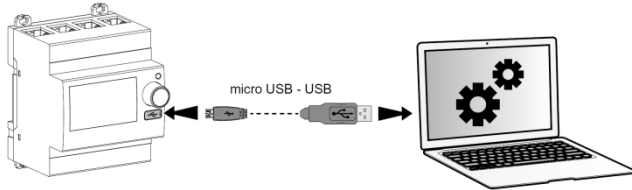

Note for Measure Module "3x single phase":

This module is to be consider as 3 modules with 3 different Modbus Address. The module takes automatically the two addresses immediately following the setting one (e.g. Programmed address = 12, Addresses of the module 12, 13, 14)

6. SYSTEM ARCHITECTURES

6.1 Stand-alone system (continued):

6.1.2 Stand-alone system with remote addressing (through a computer) (continued):

Consequences for the system architecture:

- for 1 mini configuration module (cat. no F80BV)
 - o up to **30 EMS BTDIN modules** (e.g. 30 devices grouped per functions with addresses from 1 to 30)

It is possible to assign to several devices the same address with the purpose of grouping different functions, **because they are related to the same electrical circuit**. For example, it is possible to assign the same address to a signalling auxiliary module (cat. no F80BCR), a universal control module (cat. no F80BC), a measuring module, and so on. In this way on the EMS BTDIN display or in a supervision system the grouped function will be displayed as a unique "device" with all grouped functions. [Refer to the schemes here under]

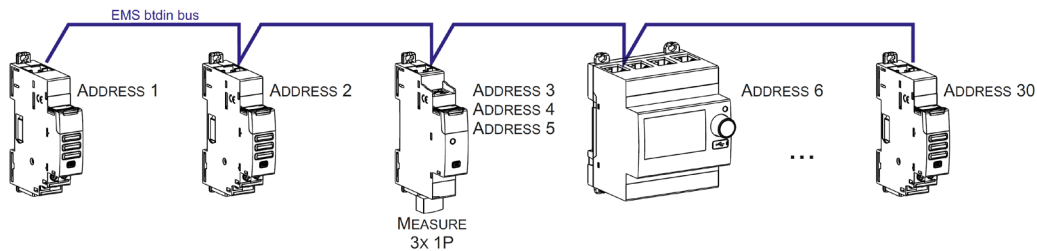

Note for the mini configuration module (local display)

.It is necessary to assign the mini configurator a different address from all the other EMS BTDIN modules through the device programming menu

. The mini configuration module can be placed everywhere in the EMS BTDIN bus

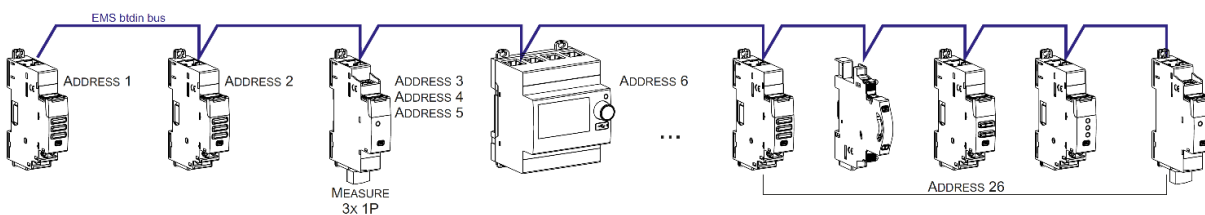

6.2

Supervised system (Computer Supervisory System)

. **Supervised system** = System to be used through a Computer Supervisory System to remotely read data from the EMS BTDIN devices and/or do operations on these devices (e.g. commands of a motor driven or contactor ...).

6.2.1 Supervised system-with local addressing (through the track wheel)

Local addressing advantages:

- No configuration software needed to set-up the installation
- Installation can be done without the intervention of a System Integrator

Programming procedure:

. For EMS BTDIN modules which need some use EMS Configurator(see § "Module configuration")

Addressing procedure:

. For all EMS BTDIN modules: mandatory through the track wheel located on the top upper face of each EMS BTDIN modules

. Marked from 0 to 9 in order to locally define the Modbus address to EMS BTDIN modules

In this system the Modbus address of an EMS BTDIN module device or group of modules (several functions) is obtained considering the address of the interface Modbus/EMS BTDIN Interface as tenth and the address of a device or group of function as unit (e.g. Interface address 1 = 10 → address of module n°5 = Modbus address 15)

Note for Measure Module "3x single phase":

This module is to be consider as 3 modules with 3 different Modbus Address. The module takes automatically the two addresses immediately following to the programmed one (e.g. Programmed address = 12, Addresses of the module 12, 13, 14)

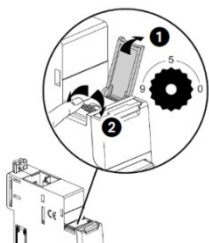

6. SYSTEM ARCHITECTURES *(continued)*

6.2 Supervised system (Computer Supervisory System) *(continued)*

6.2.1 Supervised system-with local addressing (through the track wheel) *(continued)*

Consequences of the local addressing mode (through the track wheel):

- . Each device of the system must be addressed.
- . Rotary position: from 1 to 9
- . Address 0 not permitted

It is possible to assign to several devices the same address with the purpose of grouping different functions, **because they are related to the same electrical circuit**. For example, it is possible to assign the same address to a signalling auxiliary module (cat. no F80BCR), a universal control module (cat. no F80BC), a measuring module, and so on. In this way on the EMS BTDIN display or in a supervision system the grouped function will be displayed as a unique “device” with all grouped functions. *[Refer to the scheme hereunder]*

Note: In this configuration the Modbus address of an EMS BTDIN module device or group of modules (several functions) is obtained considering the address of the interface Modbus/EMS BTDIN Interface as tenth and the address of a device or group of function as unit (e.g. Interface rotary 1 = 10 and device rotary = 5 → Modbus address = 15)

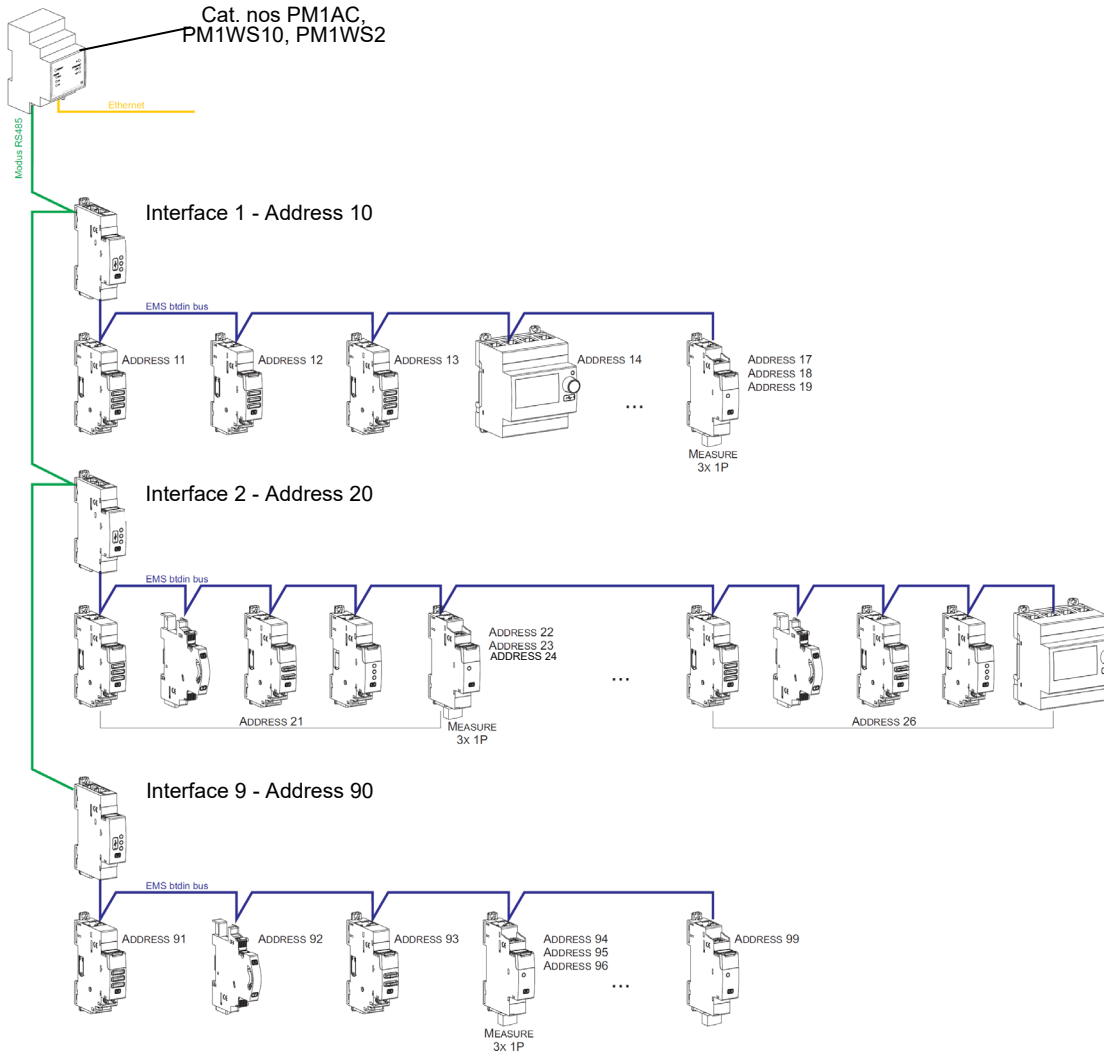

Consequences for the system architecture:

- for 1 IP/Modbus gateway (cat. no PM1AC):
 - o up to **81 Modbus address**
 - o mandatory limit of max. **9 Modbus/EMS BTDIN interfaces or max. 1000 m of Modbus cable** (cable Belden 9842, Belden 3106A or equivalent) or max. **50 m of Category 6 cable** (FTP or UTP).
- for 1 Modbus/EMS BTDIN Interface (cat. no F80BIM1):
 - o up to **30 EMS BTDIN modules** (ex. 30 devices grouped per functions with rotary from 1 to 9)

Note: with local addressing, the Modbus/EMS BTDIN interface, does the automatic detection of modules (characteristics, functions, configuration...)

6. SYSTEM ARCHITECTURES *(continued)*

6.2 Supervised system (Computer Supervisory System) *(continued)*

6.2.2 Supervised system-with remote addressing (through a computer)

Remote addressing advantages:

- Whole of configuration (addresses and functions) can be done a remotely through the EMS Configuration software
- Configuration software available for free
- **Automatic detection of the EMS BTDIN modules** installed in the system (characteristics, functions, configuration...)
- **Increased settings possibilities: load shedding function**
- Increased addressing: **up to 32 Modbus/EMS BTDIN interfaces**
- Increased addressing: **up to 247 Modbus addresses in a system**

Programming procedure:

. For EMS BTDIN modules which need use the configuration software *(see § "Module configuration")*

Addressing procedure:

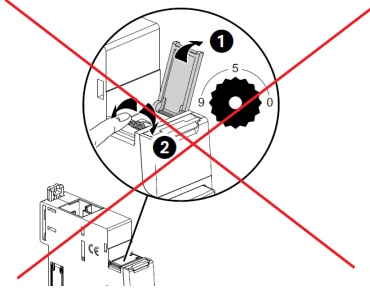

 The track wheel must be left in position "0".

. It is not necessary to assign an address via rotary; **The track wheel must be left in default position "0"**.

. All the addressing/configuring procedure will be done with the Configuration Software (available online for free)

. With remote addressing, the software does the automatic detection of modules installed in the system, but the supervision is not possible until the user assigns the remote address and all the characteristics to each module.

Note: it is mandatory to connect the computer to the different Modbus/EMS BTDIN interface with an USB-micro USB cable (one interface at a time). *[For more details, refer to the technical data sheet of the Modbus/EMS BTDIN interface]*

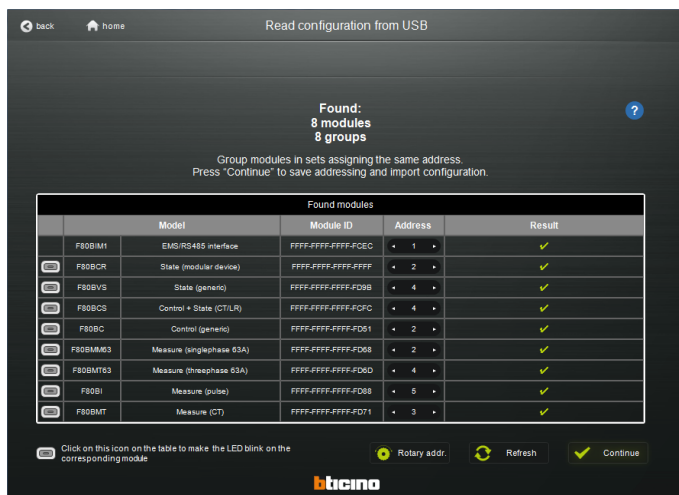
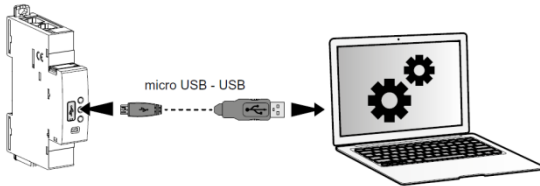

Note for Measure Module "3x single phase":

This module is to be consider as 3 modules with 3 different Modbus Address. The module takes automatically the two addresses immediately following to the programmed one (e.g. Programmed address = 12, Addresses of the module 12, 13, 14)

6. SYSTEM ARCHITECTURES *(continued)*

6.2 Supervised system (Computer Supervisory System) *(continued)*

6.2.2 Supervised system-with remote addressing (through a computer) *(continued)*

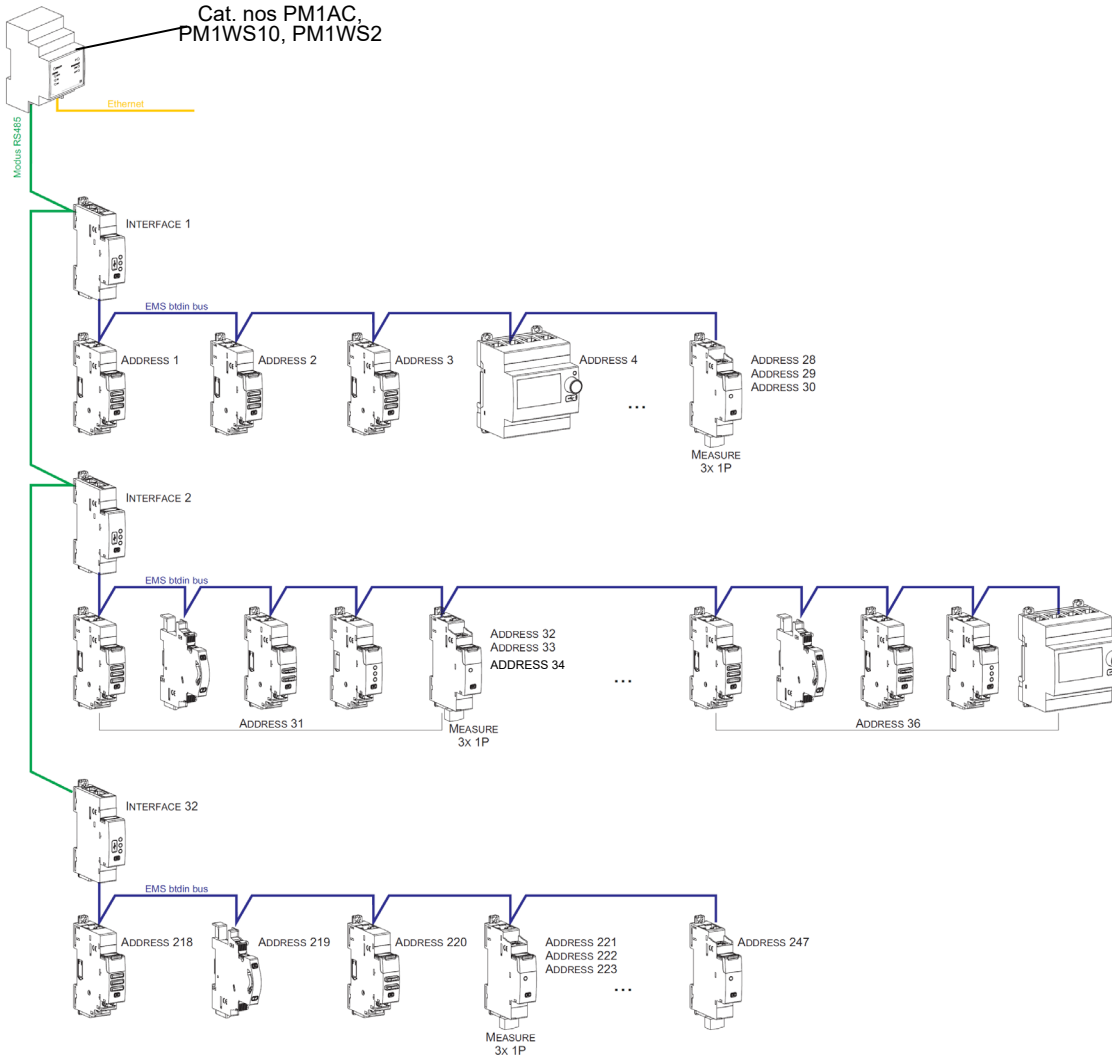

Consequences for the system architecture:

- for 1 IP/Modbus gateway (cat. no PM1AC):
 - o up to **247 Modbus address**
 - o Because of Modbus: mandatory limit of max. **32 Modbus/EMS BTDIN interfaces** or max. **1000 m of Modbus cable** (cable Belden 9842, Belden 3106A or equivalent) or max. **50 m of Category 6 cable** (FTP or UTP).
- for 1 Modbus/EMS BTDIN Interface (cat. no F80BIM1):
 - o up to **30 EMS BTDIN modules** (e.g. 30 devices grouped per functions with addresses from 1 to 30)

It is possible to assign to several devices the same address with the purpose of grouping different functions, **because they are related to the same electrical circuit**. For example, it is possible to assign the same address to a signalling auxiliary module (cat. no F80BCR), a universal control module (cat. no F80BC), a measuring module, and so on. In this way on the EMS BTDIN display or in a supervision system the grouped function will be displayed as a unique "device" with all grouped functions. *[Refer to the scheme up here]*

7. COMPLIANCE AND APPROVALS

Compliance to standards:

- . Compliance with Directive on electromagnetic compatibility (EMC) n° 2014/30/EU
- . Compliance with low voltage directive n° 2014/35/EU.
- . Electromagnetic Compatibility:
 - IEC/EN 61131-2
 - IEC/EN 60947-5-1

Environment respect - Compliance with EU directives:

- . Compliance with Directive 2011/65/EU as amended by Directive 2015/863 (RoHS 2) on the restriction of the use of certain hazardous substances in electrical and electronic equipment.
- . Compliance with REACH regulation (1907/2006): at the date of the publication of this document no element of the SVHC substance list (updated on 27/06/2018) is present in these products.
- . WEEE directive (2012/19/EU): the sale of this product is subject to a contribution to eco-organisations in each country responsible for managing end-of-life products in the field of application of the European Waste Electronic and Electrical Equipment Directive.

Plastic materials:

- . Halogens-free plastic materials.
- . Marking of parts according to ISO 11469 and ISO 1043.

Packaging:

- . Design and manufacture of packaging compliant to decree 98-638 of the 20/07/98 and also to directive 94/62/CE.

Environmental profile:

- . PEP document available